

# Floor Openings in Two-Way Slabs

BY MICHAEL C. MOTA AND MAHMOUD KAMARA

If you took an advanced concrete design course, you probably had a good introduction to the design of two-way slabs. Although all multistory buildings require multiple small slab penetrations for routing of plumbing, fire protection piping, and ductwork between floors and larger openings for stairwells and elevator shafts, your course probably covered the topic of slab openings only briefly (if at all).

For newly constructed slabs, the locations and sizes of the required openings are usually determined in the early stages of design and can be easily accommodated in the majority of instances. However, you may also be asked to modify an existing structure, where the analysis and strengthening (if required) are typically more involved than for similar openings in a new slab.

In this article, we'll give you some guidance on selecting locations and sizes for openings in two-way slabs for both new and existing structures. By carefully selecting their locations, small openings can often be accommodated without requiring strengthening. You'll probably run across situations, however, where the opening requires strengthening or the location of these openings is dictated by concerns other than the strength of the structure. For these cases, we'll also introduce some methods for strengthening existing structures.

## TYPES OF TWO-WAY SLABS

Although there are several different variations of two-way slabs, they can be generally described as one or a combination of three two-way systems: flat plates, flat

slabs, and two-way beam-supported slabs. The selection of the most advantageous location for a floor opening depends on the type of two-way slab you're designing or evaluating.

The simplest type of two-way slab to construct is known as a flat plate. These slabs are supported directly by the columns and have a completely flat soffit. For live loads of about 50 psf (2.5 kPa), column spacing typically ranges from 15 to 25 ft (4.5 to 7.5 m) with minimum slab thicknesses of 6 to 10 in. (150 to 250 mm).<sup>1</sup> For longer spans, drop panels (thickened portions of the slab) are added at the columns. This system is referred to as a flat slab and has an economical span range of 25 to 30 ft (7.5 to 9 m) with minimum slab thicknesses of 8.5 to 10 in. (200 to 250 mm). Two-way beam-supported slabs have beams spanning between columns in both directions that act with the slab to support gravity loads.

## OPENINGS IN NEW SLABS

For the purposes of design, two-way slab systems are divided into column and middle strips in two perpendicular directions. The column strip width on each side of the column centerline is equal to 1/4 of the length of the shorter span in the two perpendicular directions. The middle strip is bounded by two column strips.

Section 13.4.1 of ACI 318-05<sup>2</sup> permits openings of any size in any new slab system, provided you perform an analysis that demonstrates both strength and serviceability requirements are satisfied. As an alternative to detailed analysis for slabs with openings, ACI 318-05 gives the

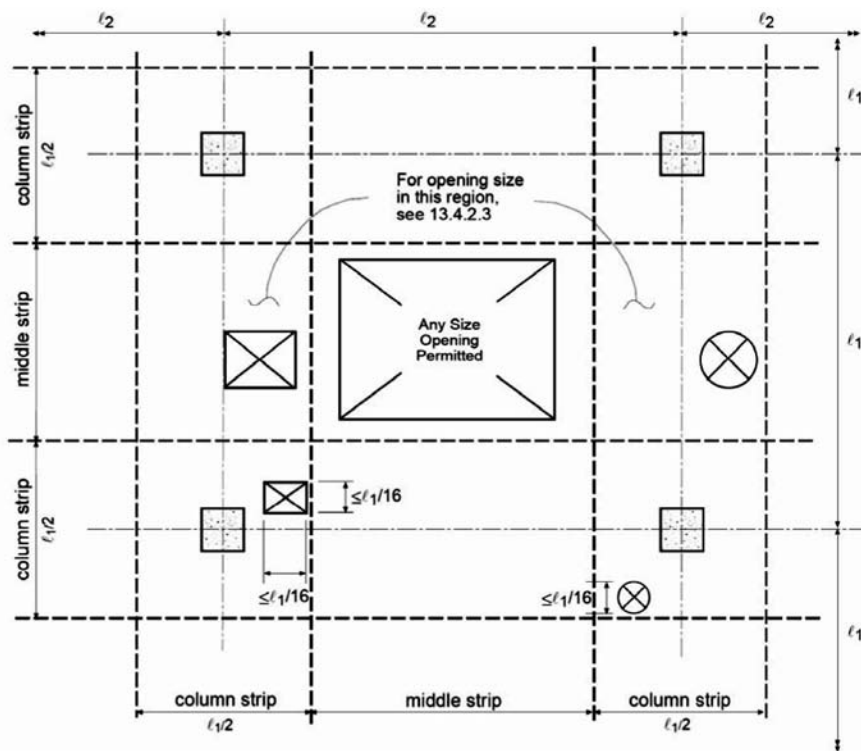

**Fig. 1: Suggested opening sizes and locations in flat plates with  $l_2 \geq l_1$  (from Reference 3)**

following guidelines for opening size in different locations for flat plates and flat slabs. These guidelines are illustrated in Fig. 1 for slabs with  $l_2 \geq l_1$ :

- In the area common to intersecting middle strips, openings of any size are permitted (Section 13.4.2.1);
- In the area common to intersecting column strips, the maximum permitted opening size is  $1/8$  the width of the column strip in either span (Section 13.4.2.2); and
- In the area common to one column strip and one middle strip, the maximum permitted opening size is limited such that only a maximum of  $1/4$  of the slab reinforcement in either strip may be interrupted (Section 13.4.2.3).

To apply this simplified approach, ACI 318-05 requires that the total amount of reinforcement calculated for the panel without openings, in both directions, must be maintained; thus, half of the reinforcement interrupted must be replaced on each side of the opening.

In addition to flexural requirements, the reduction in slab shear strength must also be considered when the opening is located anywhere within a column strip of a flat slab or within 10 times the slab thickness from a concentrated load or reaction area. The effect of the slab opening is evaluated by reducing the perimeter of the critical section  $b_o$  by a length equal to the projection of the opening enclosed by two lines extending from the centroid of the column and tangent to the opening, as shown in Fig 2(a). For slabs with shearheads to assist in transferring slab shear to the column, the effect of the opening is reduced, and  $b_o$  is reduced by only half the length enclosed by the tangential lines, as shown in Fig. 2(b).

## OPENINGS IN EXISTING SLABS

Small openings in existing slabs are usually core-drilled to the required diameter. Larger openings are cut with a circular saw or a concrete

chain saw with plunge cutting capabilities. Because a circular saw makes a longer cut on the top of the slab than on the bottom, small cores drilled at the corners can be used to help avoid over-cutting the opening when a circular saw is used.

Cutting openings in existing slabs should be approached with caution and avoided if possible.<sup>4</sup> When cutting an opening in an existing slab, the effect on the structural integrity of the slab must be analyzed. It's advisable to analyze the slab for excess capacity and possible moment redistribution before making the final decision on the sizes and locations of the openings, but the following guidelines taken from Reference 4 can assist you in making preliminary decisions with the best chance to avoid having to reinforce the slab.

## Openings in existing flat plates and flat slabs

Because the punching shear capacity of the slab around the columns typically governs the thickness of flat plates, any openings at the intersection of column strips (Area 3 in Fig. 3) should be avoided as much as possible. This is especially critical near corner and edge columns where the shear in the slab is typically highest. If openings must be made in Area 3, to install a drainage pipe for example, the size of the opening should be no larger than 12 in. (300 mm). Because they reduce the critical section for resisting punching shear (as explained in Section 11.12.5 of ACI 318-05), openings cut in this area should be evaluated carefully. One possible exception to this guideline is when column capitals, commonly seen in older structures, are present to reduce shear stresses in the slab.

Openings in Area 2, located at the intersection of column and middle strips, are less critical than in Area 3, and small openings having a width less than 15% of the span length can often be made in this area. The most

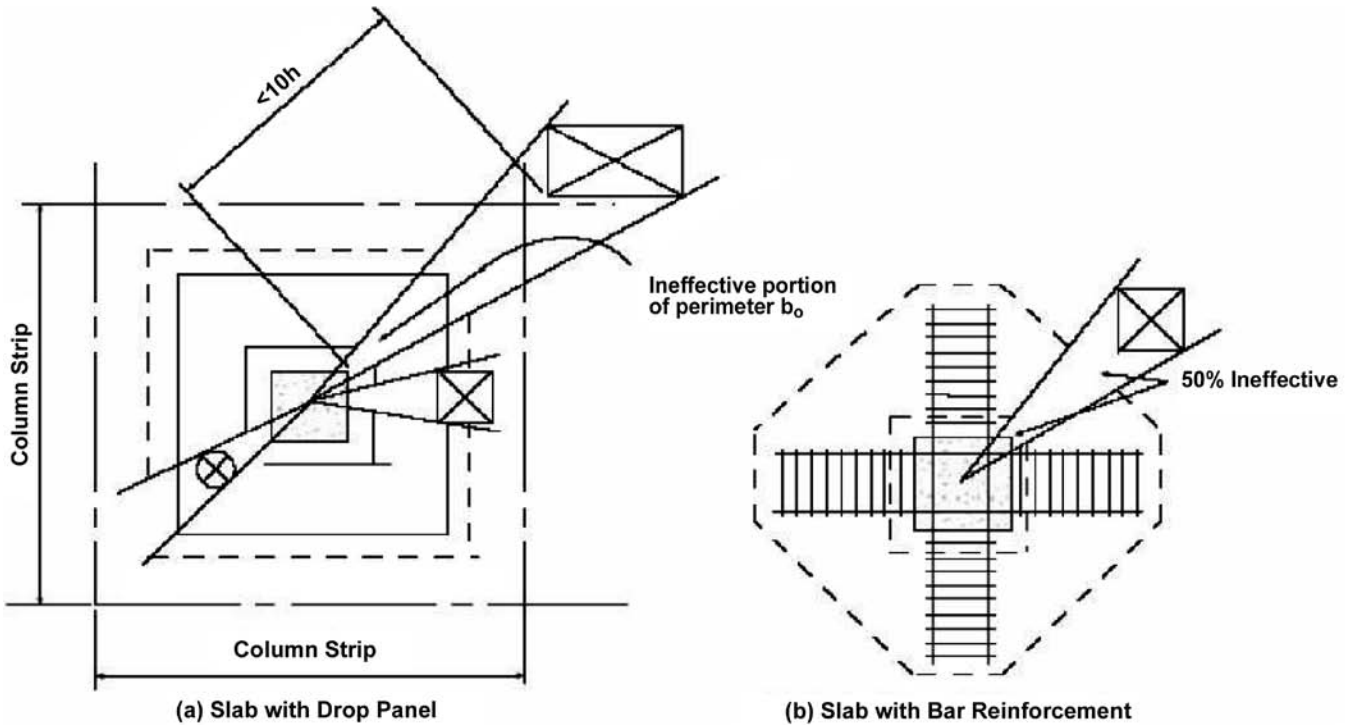

**Fig. 2: Reduction to perimeter of critical section  $b_o$  for a flat plate or flat slab with openings in column strips or within a distance of 10 times the thickness of the slab from a column: (a) no shearheads; and (b) with shearheads (from Reference 3)**

favorable location for openings from a structural point of view is often the intersection of two middle strips (Area 1). This is also often the least favorable location from an architectural point of view, however, because it's the most disruptive to the function of the space.

The guidelines for openings in flat slabs generally follow the recommendations for flat plates, but the chances of accommodating larger openings in Area 3 are increased due to the lower shear stresses in the region of the drop panels.

## Openings in existing two-way beam-supported slabs

For openings in two-way beam-supported slabs, the situation is reversed because much of the shear is transferred to the column through the beams. The total width of openings in Area 3 (intersection of two column strips) can often be up to 1/4 of the span, as long as the beams are left intact. Openings in Area 2 can be more problematic because they may intersect the portion of the slab used as a T-beam. Although Area 1 is the least desirable location, openings with maximum dimensions up to 1/8 of the span can often be located at the intersection of two middle strips.

When removing an entire panel of slab between beams, it's often an advantage to leave enough of an overhang to allow development of reinforcing bars from adjacent spans. In this case, the beams should be checked for

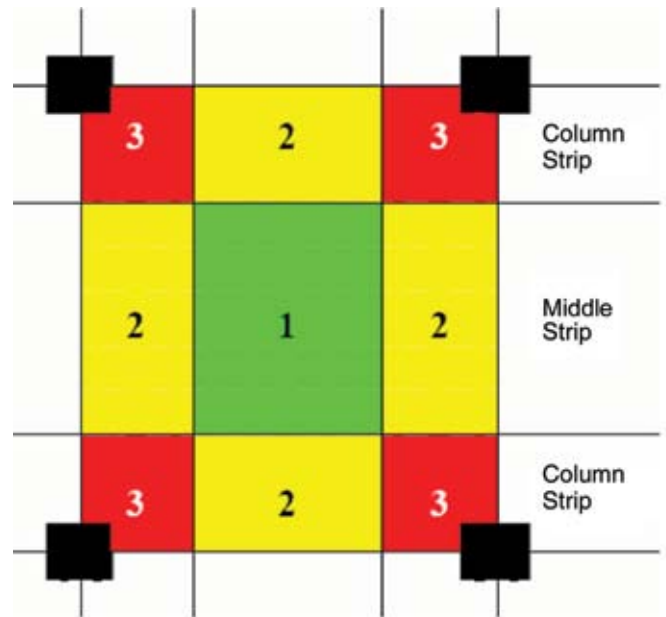

**Fig. 3: Areas for slab openings (after Reference 4)**

torsion because the balancing moments from the portion of the slab that was removed will no longer be present.

## STRENGTHENING METHODS

Openings in new structures can often be accommodated by the proper detailing of additional reinforcing steel in

# Practical Design: A Supplement to Academics

the slab or beams, beams spanning between columns or other beams, or thickening of portions of the slab around openings. When you determine that an existing structure can't accommodate new openings without strengthening, the situation becomes more complex; however, there are several common strengthening methods you can consider.<sup>5</sup> The selection of the most appropriate method to use will depend on several factors, such as the amount of strengthening required, the location where strengthening is required, and architectural requirements.

One of the most common methods for increasing moment capacity is to add steel plates to the surface of a slab, using either through-bolts or post-installed anchors. The installation is fairly simple, but because plates and through-bolts would interfere with flooring surfaces, plates are normally installed on the bottom of the slab using post-installed anchors. Also, because overlapping of the plates is difficult, this method works best when strengthening is required in only one direction.

A similar method is to use fiber-reinforced polymer or steel-reinforced polymer strips to strengthen the slab. The strips can be overlapped at the corners of the opening, making strengthening in two directions simpler, and does not interfere with the floor surface as much as anchored steel plates. Their installation, however, requires more highly skilled labor.

When there are existing concrete beams, steel beams can be installed that span between the concrete beams. Shims or nonshrink grout should be installed between the top flange of the steel beam and the bottom of the slab to ensure uniform bearing.

When shear strengthening is required around columns, a common solution is to install steel or concrete collars around the columns to increase the perimeter of the critical section for punching shear.

It's important to remember that exposed reinforcing systems may require fire protection. Systems that incorporate epoxy adhesives must be carefully evaluated, as they can lose strength rapidly at elevated temperatures. For low levels of strengthening, the contribution of the exposed reinforcing system to the strength of the slab can be neglected, and the strength checked using factored loads for fire conditions that are lower than under normal temperatures. For higher levels of strengthening, special coatings may be required to achieve a specific fire rating.<sup>6</sup>

## SEEK ADVICE

Experience is one of the most valuable tools when selecting opening locations and strengthening methods. Your first few projects would be an excellent opportunity to seek the advice of more experienced engineers in your company. They may be able to show you what they've

done on previous projects, provide you with typical details, and give their thoughts on which locations and strengthening methods would work best for your particular situation.

## References

1. "An Engineers Guide to: Economical Concrete Floor Systems," Portland Cement Association, Skokie, IL, 2005, 6 pp.
2. ACI Committee 318, "Building Code Requirements for Structural Concrete (ACI 318-05) and Commentary (318R-05)," American Concrete Institute, Farmington Hills, MI, 2005, 430 pp.
3. *Notes on ACI 318-05 Building Code Requirements for Structural Concrete with Design Applications*, M.E. Kamara and B.G. Rabbat, eds., Portland Cement Association, Skokie, IL, 2005, 1008 pp.
4. Newman, A., *Structural Renovation of Buildings—Methods, Details, and Design Examples*, McGraw-Hill, New York, NY, 2001, pp. 239-246.
5. Alkhrdaji, T., and Thomas, J., "Keys to Success: Structural Repair and Strengthening Techniques for Concrete Facilities," *Structural Engineer*, V. 5, No. 4, May 2004, pp. 24-27.
6. Alkhrdaji, T., "Concrete Q&A: Design Considerations for Fire Resistance of Structural Strengthening System," *Structural Engineer*, July 2004, available at [www.gostructural.com](http://www.gostructural.com).

Selected for reader interest by the editors.



ACI member **Michael C. Mota** is a Regional Engineering Manager for the Portland Cement Association (PCA), providing technical assistance in all areas of building design throughout the eastern U.S. He received an MS in structural engineering from the New Jersey Institute of Technology, Newark, NJ, and practiced structural engineering and construction management for more than 5 years prior to joining PCA. He is a member of ACI Committees 314, Simplified Design of Concrete Buildings; 375, Performance-Based Design of Concrete Buildings for Wind Loads; and 435, Deflection of Concrete Building Structures.



ACI member **Mahmoud Kamara** is a Senior Structural Engineer at PCA. He is involved in developing technical publications, coordinating and conducting seminars, and assisting in developing structural engineering software. He serves on several ACI technical committees and is a member of the American Society of Civil Engineers. In 1992, he received the ACI Structural Research Award.